

### WATERLINK 2 CIRCOLATORI 4 TUBI

POS	DESCRIZIONE
1	SCAMBIATORE 34 PIASTRE
2	VALVOLE DI SFIATO AUTOMATICHE G3/8"
3	CIRCOLATORI WILO YONOS PARA RS15/6 RKC

### SCHEMA IDRAULICO

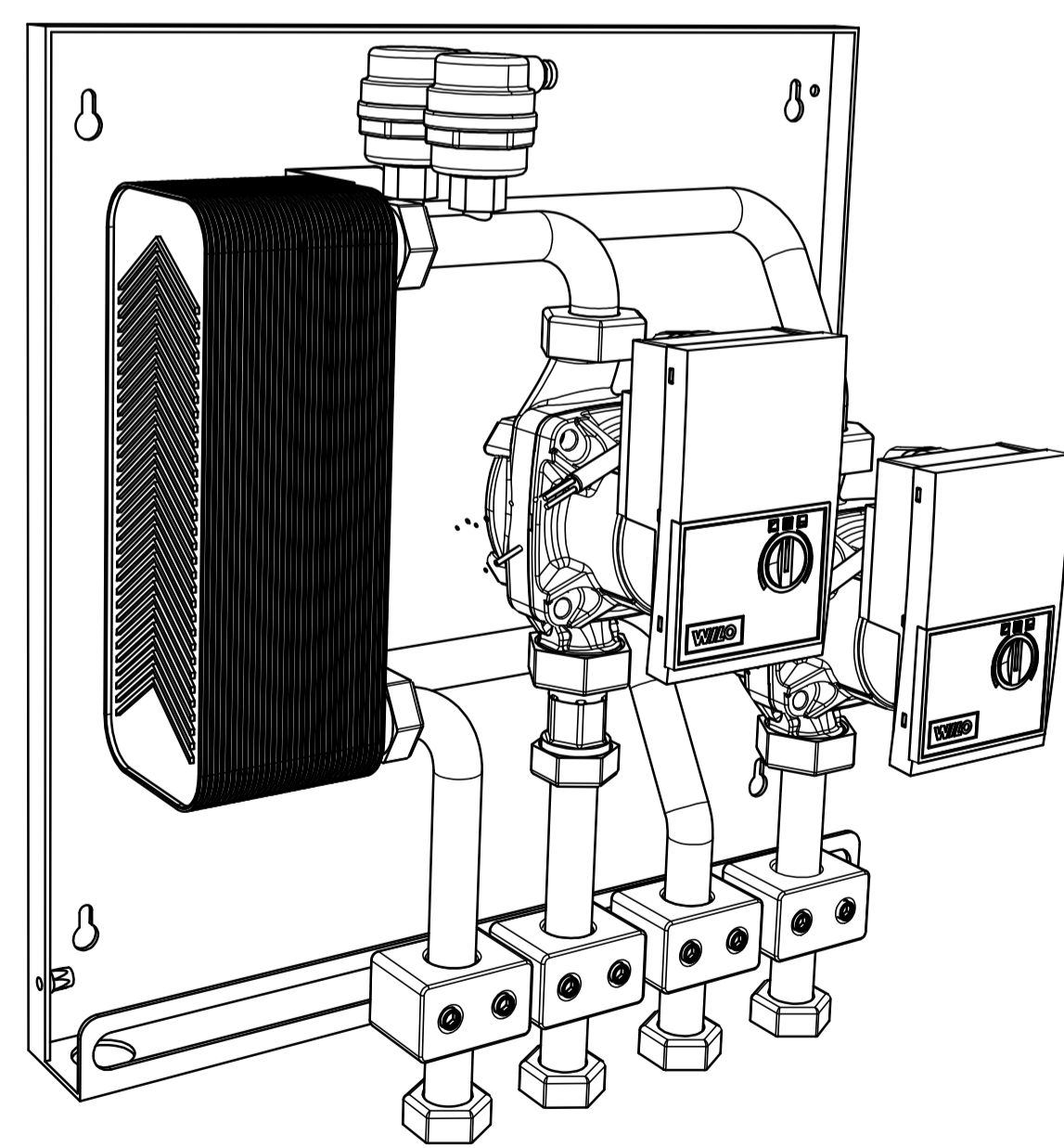
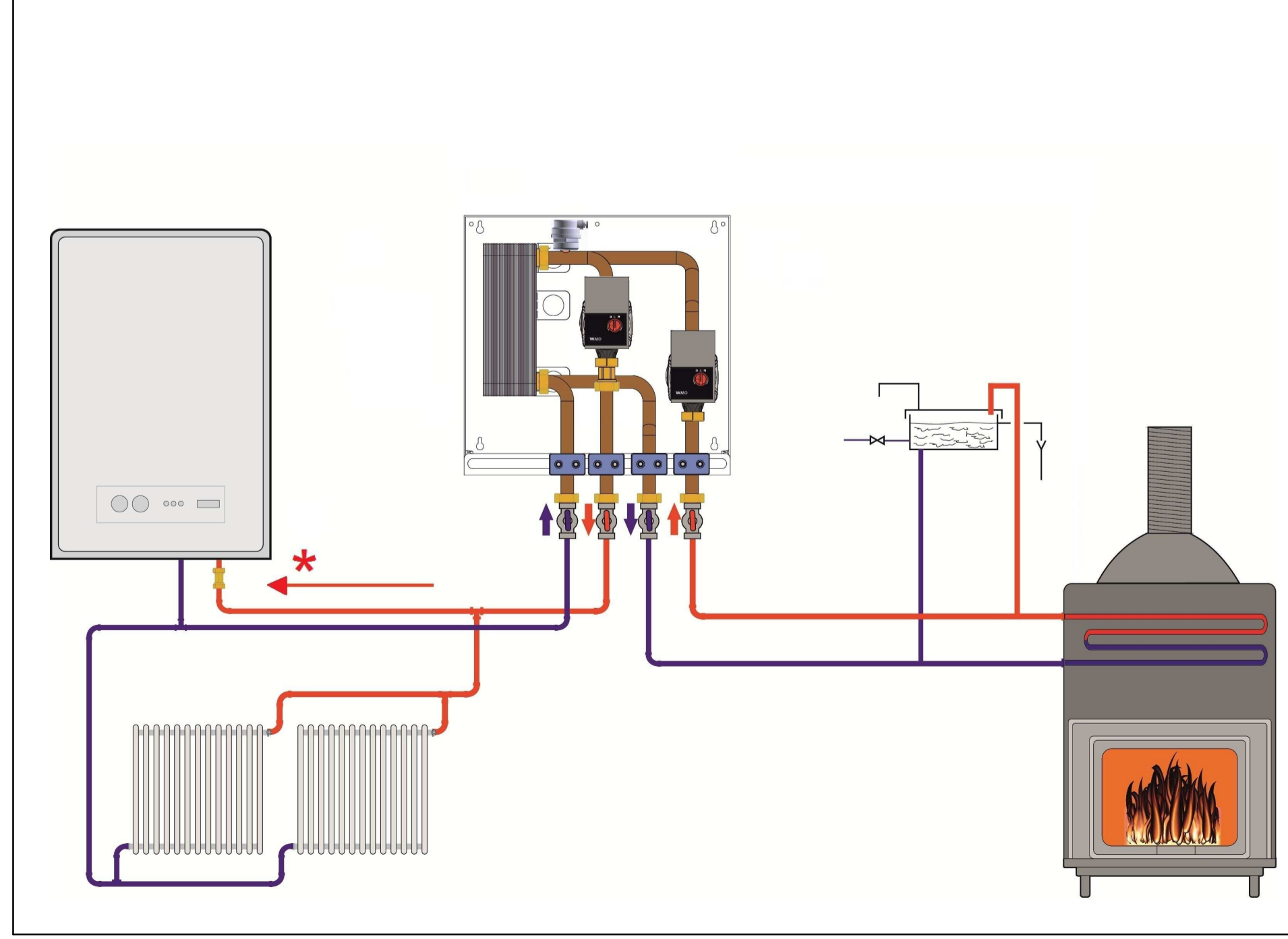

Verificato			
Peso grezzo		Date senza indicazione di tolleranze: precisione gruppo	
Peso finito		Lunghezza (sta minore)	
Proprietà		Disegno/Codice	
Disegno		Data	
Scala		Verif.	
Denominazione		del	
AI		561592	
WATERLINK ERP COMPATTO 2 CIRCOLATORI 4 TUBI 34 PIASTRE		IMIT CONTROL SYSTEM	