

ELETTROPOMPE DA DRENAGGIO drainage electric pumps

XKS ELETTROPOMPE SOMMERGIBILI IN ACCIAIO INOX STAINLESS STEEL SUBMERSIBLE PUMPS

APPLICAZIONE

• Elettropompa leggera e maneggevole, la sua affidabilità è garantita da una doppia protezione contro infiltrazioni, ottenuta con tenuta meccanica e guarnizione. Tutti i componenti delle elettropompe XKS sono stati realizzati seguendo le direttive WEE, ROHS, PAHS, che ne garantiscono la totale sicurezza

UTILIZZO

- Temperatura del liquido fino a: +35°C
- Temperatura ambiente fino a: 40°C
- Profondità massima di immersione: 7mt

DATI TECNICI

- Alimentazione 230-240V/50Hz
- Cavo H05RN-F 10mt
- Girante PPO
- Classe di isolamento: F
- Grado di protezione: IPX8

APPLICATION

• It is mainly used for water drainage in the pond, miniature landscape, bathing, domestic cultivation and solar water supply place etc. It can also be used for small equipment and water supply system for facilities.

OPERATING LIMITS

- Fluid temperature up to 35°C
- Ambient temperature up to 40°C
- Max immersion depth: 7 m

TECHNICAL DATA

- Supply power 220-240V/50Hz
- Cable H05RN-F 10m
- Impeller PPO
- Insulation class: F
- Protection class: IPX8



Per acqua pulita | Clean Water



Per acqua carica | Dirty Water

Codici identificativi | Identification Codes

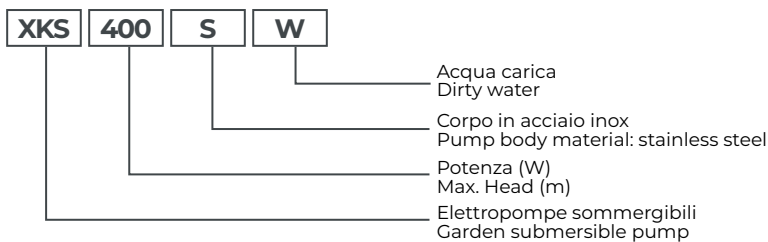

Vortex

Dati tecnici | Technical Data

Mod. Acqua pulita Mod. Clean Water	Alimentazione Supply power	Potenza Power		Ampere	Prevalenza max. Max. head	Portata max. Max. flow	Max diam particelle Max. dia. of particle	Uscita Outlet	Cavo Cable	Codice Code	€ cad € each
		kW	HP								
XKS400S	220-240V/50Hz	0.40	0.60	2.00	7mt	9m ³ /h	5mm	1 1/4"	H05RN-F 10mt	10XKS400S	156,00
Mod. Acqua Carica Mod. Dirty Water	Alimentazione Supply power	Potenza Power		Ampere	Prevalenza max. Max. head	Portata max. Max. flow	Max diam particelle Max. dia. of particle	Presa Outlet	Cavo Cable	Codice Code	€ cad € each
		kW	HP								
XKS750SW	220-240V/50Hz	0.75	1.00	3.50	8mt	12m ³ /h	35mm	1 1/2"	H07RN-F 10mt	10XKS750SW	204,00

Dimensioni | Dimension

Modello Model	DN	L (mm)	W (mm)	H (mm)
XKS400S	32	151	151	323
XKS750SW	40	165	248	351

Dimensioni imballo | Package information

Modello Model	GW (kg)	L (mm)	W (mm)	H (mm)
XKS400S	5.2	200	150	300
XKS750SW	7	210	165	350



Diagramma prestazioni | Hydraulic Performance Curve

XKS400S

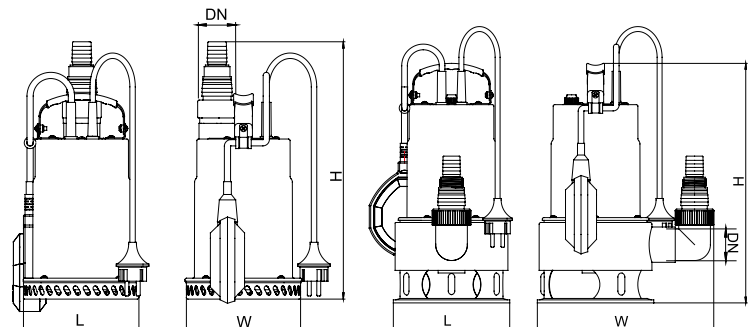
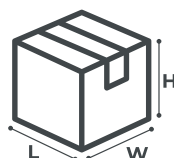
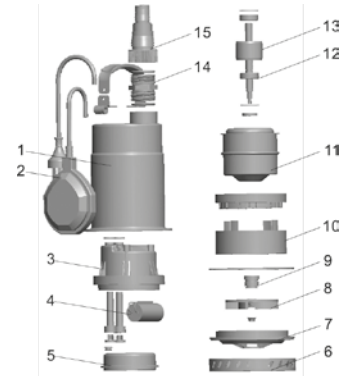
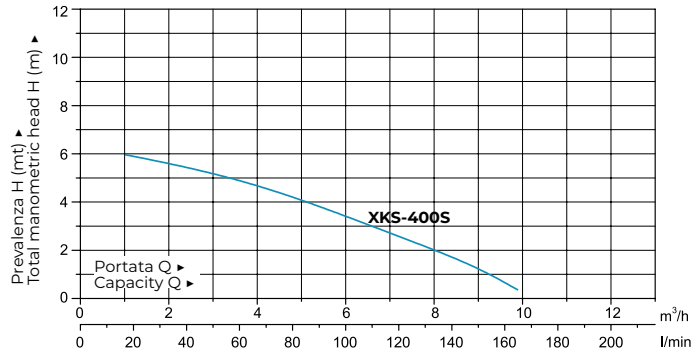

Descrizione componenti | Materials Table

Pos.	Part.	Mat.	Pos.	Part.	Mat.	Pos.	Part.	Mat.
1	Involucro pompa Pump cover	AISI 304	6	Base Pump base	AISI 304	11	Statore Stator	
2	Interruttore a galleggiante Float switch		7	Diffusore Diffuser	Termoplastica PP	12	Cuscinetto a sfera Ball bearing	
3	Coperchio superiore Upper cover	Termoplastica PP	8	Girante Impeller	Tecnopolimero PPO	13	Albero motore Rotor	
4	Condensatore Capacitor		9	Tenuta meccanica Mechanical seal	Grafite/Ceramica Carbon/Ceramic	14	Connettore Connector	Termoplastica PP
5	Piatto superiore Upper plate	Alluminio ZL102	10	Supporto Pump support	ABS	15	Connettore Connector	Termoplastica PP

XKS750SW

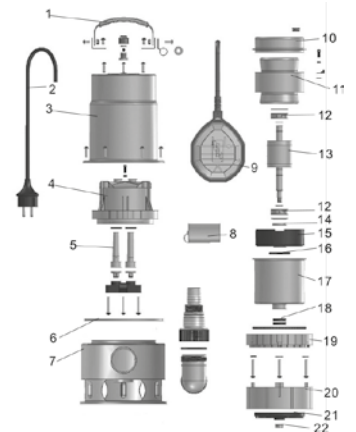
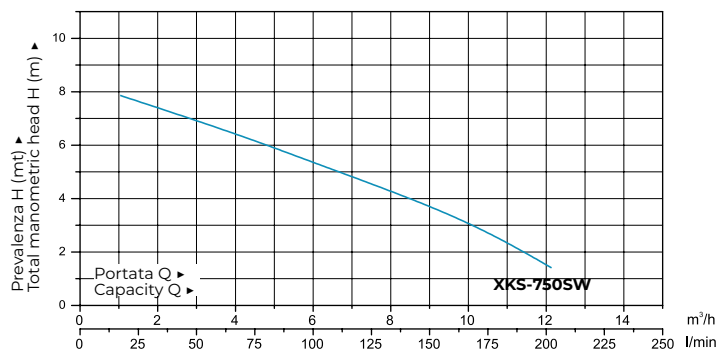

Descrizione componenti | Materials Table

Pos.	Part.	Mat.	Pos.	Part.	Mat.	Pos.	Part.	Mat.
1	Maniglia Handle	AISI 304	9	Interruttore a galleggiante Float switch	Termoplastica PP	17	Involucro Canister	Acciaio Stainless
2	Cavo Cable	Gomma Rubber	10	Coperchio superiore Upper cover		18	Tenuta a labbro Lip seal	
3	Involucro pompa Pump body	AISI 304	11	Statore Stator		19	Anello di tenuta Retainer ring	Termoplastica PP
4	Coperchio superiore Roof	Termoplastica PP	12	Cuscinetto Bearing		20	Supporto Pump support	ABS
5	Passacavo Jacket	NBR	13	Albero motore Rotor		21	Girante Impeller	Tecnopolimero PA6
6	O-ring O-ring	NBR	14	Tenuta a labbro Lip seal		22	Dado Nut	AISI 304
7	Corpo pompa Pump body	AISI 304	15	Base cuscinetto Bearing base	MMPO			
8	Condensatore Capacitor		16	O-ring O-ring	NBR			